

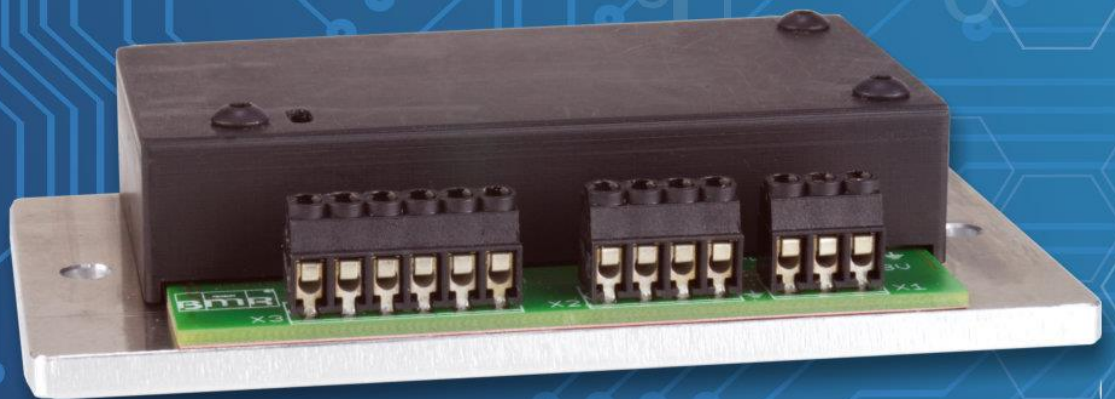

The Sign of Quality  
Made in Germany

# SFU 400

Schnellfrequenzumrichter  
High Frequency Converters



# Content

Issue Mai 2022

Rev. 1.3

<b>1</b>	<b>Description and Features</b>	<b>2</b>
<b>2</b>	<b>Technical Data</b>	<b>2</b>
<b>3</b>	<b>Safety Precautions and Warnings</b>	<b>3</b>
<b>4</b>	<b>Connections, Plugs and PIN Assignments</b>	<b>4</b>
4.1	Power Supply Connection X1	4
4.2	Spindle Connection X2	4
4.3	Interface RS232	4
4.4	Input and Output Connections X3	5
4.5	Connection and Mounting	5
<b>5</b>	<b>Functions, Setup and Operation,</b>	<b>6</b>
5.1	Start and Stop	6
5.2	Set Value of Rotational Speed	6
5.3	Outputs	6
5.4	LED Status Indication	7
5.5	Example for I/O Connection	8
<b>6</b>	<b>Safety Functions</b>	<b>9</b>
<b>7</b>	<b>EMC</b>	<b>9</b>
<b>8</b>	<b>USB Interface Adapter</b>	<b>10</b>
<b>9</b>	<b>Remote Control Unit</b>	<b>11</b>
<b>10</b>	<b>Dimensions and Mounting</b>	<b>12</b>

## 1. Descriptions and Features SFU400

- ✓ The SFU400 is developed for the operation of **AC-asynchron-** and **DC-synchron-spindles.**
- ✓ **speed frequencies** up to **1666Hz/100.000 rpm** with this 2-pole AC spindle are possible
- ✓ The core of **SFU400** is a **digital signal processor (DSP)** which produces all output parameters and collects signals.
- ✓ **High-precision sinusoidal** output signals with a low distortion factor and low deformation allow for optimal rotation qualities in AC motors of all operating conditions.
- ✓ All parameters like power, voltage and frequency are collected in **real time** and are regulated by the implemented vector control depending on the load.
- ✓ High **operating safety:** All operating conditions like acceleration, operation with nominal rotation speed, braking are controlled and critical conditions are intercepted.
- ✓ **Short circuit protected**
- ✓ **on board chopper brake resistor**
- ✓ **Protection against excess temperature**

## 2. Technische Daten

<b>Power Supply</b>	Connection: <b>X1</b> 24V...48V <sub>DC</sub> (+10%)/ 7A No protection against faults due to reversed polarity	Screw Terminals for strands or wires up to 0,75mm <sup>2</sup> with PE Connection at <b>X1</b>
<b>Fuses</b>	FS1: internal recommended external fusing: 6AT	7AT/63V SMD
<b>Continuous Output Power</b>	380VA / S1 100%	
<b>Spindle Connection</b>	Connection: <b>X2</b> 3-pol.:	Spring clamps for strands or wires up to 0,75mm <sup>2</sup> U, V, W, with PE connection <b>X2</b>
<b>Output Voltage</b>	max. 32 V <sub>AC</sub>	PWM: 28kHz
<b>Output Current</b>	Phasen Current 7A	
<b>Brake Chopper Resistor</b>	on board 540ohms / 4W / threshold voltage: 54V	
<b>Output Frequency</b>	AC: 1.666 Hz / max.100.000 rpm @ 2pol Spindle	
<b>Control Inputs</b>	Connection: <b>X3</b> Digital In:  Analog In:	Screw Terminals for strands or wires up to 0,75mm <sup>2</sup> Start / Stopp ( 0 / 24V ) "0": 0..5V, "1": 13..24V permissible voltage range -3V...30V <sub>DC</sub> I <sub>max</sub> @ 24V = 10mA Duty value rotational speed ( 0..10V ) Min-Max R <sub>in</sub> : 60kOhm, 10bit
<b>Control Outputs</b>	Connection: <b>X3</b> 2 x Digital Out: no short circuit protection inductive loads must be protected externally by diodes	Screw Terminals for strands or wires up to 0,75mm <sup>2</sup> Open Collector; 45V/0,5A
<b>Interface</b>	Anschluss: <b>X4</b>	RS232, 115kBd
<b>Indicators</b>	2 x LEDs green - red Status Display with different blink codes	
<b>Dimensions (L xW x H)</b>	73 x 53 x 14 mmon mounting plate 100mm x 53mm x 21mm	
<b>Operating Conditions</b>	5°C bis 40°C / no condensation	

### 3. Safety-Precautions and Warnings

- ✓ The SFU400 inverter is a built-in device intended for installation in stationary electrical, industrial and commercial installations or machines. When installed in machines, it is forbidden to commission the inverter and thus start its intended operation until the machine complies with the Machinery Directive 2006/42/EC. EN 60204 (DIN VDE 0113) must be observed. The machine may only be put into operation for its intended purpose if the EMC Directive (2004/108/EC) is observed.
- ✓ This device produces dangerous electrical voltages and is used for the operation of fast spinning tools. Because of their high rotational speed, it may be dangerous in case of improper handling. For this reason, only professionally trained and qualified personnel should be allowed to work with and setup this device!
- ✓ Before the first commissioning can be carried out, it should be ensured that the spindle and the tool are fixed properly, to eliminate all dangers because of uncontrolled movement of the spindle.
- ✓ Safety regulations being valid for the country where the device is used, have to be adhered to where any work is carried out on the device.
- ✓ Before the device is turned on for the first time, it should be verified, that the connected parts cannot carry out uncontrolled movements.
- ✓ The frequency converter must not be operated close to heating devices or magnets or devices generating strong magnetic fields.
- ✓ Sufficient air circulation around the converter should be ensured.
- ✓ Fluids should be prevented from intruding into the housing. If it seems to be happened, the converter has to be switched off immediately.
- ✓ The ambient air must not use aggressive, flammable or electrically conductive substances and should be as free of dust as possible.
- ✓ All repairs and maintenance on the converter and the relating accessories must be carried out by skilled personal and with powered off, only. To ensure this, the mains plug should be pulled out. In doing this, both the terms of regulations for preventing accidents and the general and national rules for mounting and safety have to be applied.
- ✓ All people who work with this device should be trained and instructed by their line advanced technician.



#### **Attention:**

**Please verify before that all voltages are correct in value and polarity.  
Connection X1 is not equipped with a polarity protection!**

## 4. Connection, Plugs and Pin Assignments

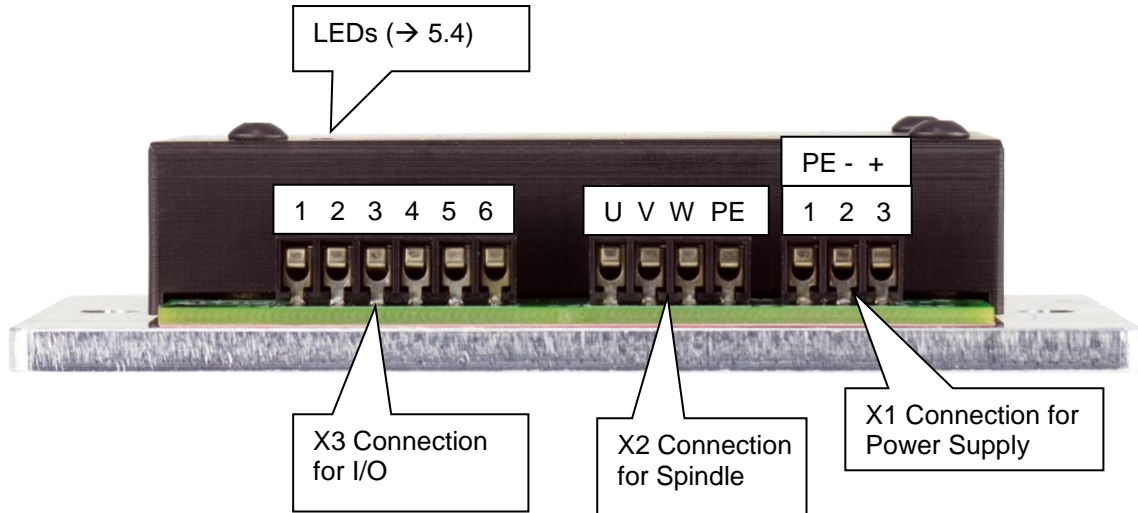

### 4.1 Power Supply Connection X1 (Screw terminals for strands or wires up to 0,75mm<sup>2</sup>)

Pin	Function	Beschreibung/Description
1	PE	Protection Earth, electrically connected with mounting plate
2	0V	GND - Return of Power Supply
3	+48VDC	+Power Supply -> Fuse FS1 7AT

Attention, no protection against reversed polarity!

### 4.2 Spindle Connection X2 (Screw terminals for strands or wires up to 0,75mm<sup>2</sup>)

Pin	Description
U	Spindle Phase U
V	Spindle Phase V
W	Spindle Phase W
PE	Protection Earth, electrically connected with mounting plate

### 4.3 Interface RS232 Connection X4 (Pin Header Würth WR-WTB\_648103131822)

1	GND
2	RxD
3	TxD



Attention, Interface is not galvanically isolated! X4.3 GND is connected with X2.2 0V.

#### 4.4 Inputs and Outputs Connection X3 (Screw terminals for strands or wires up to 0,75mm<sup>2</sup>)

Pin	Function	Description
1	DIG_IN	Digital Input1 - <b>Start / Stopp</b>
2	ANL_IN	Analog Input1 - Set Value <b>Rotational Speed</b>
3	GND	Ground for Pin 1, 2, 4, 5 (internally connected with X1-0V)
4	OUT 1	Open Collector1 <b>Converter and Spindle ready</b>
5	OUT 2	Open Collector2 <b>Overload</b>
6	PTC	Temp Sensor Input Spindle - Threshold variable to be set up

Input Impedance ANL\_IN: 60kOhm,                      DIG\_IN I<sub>max</sub> @ 24V: 10mA  
 Open Collector: 45V/0,5A

A Remote Control Unit is available on option for direct connection with the I/O (→ 9.).

#### 4.5 Connection and Mounting

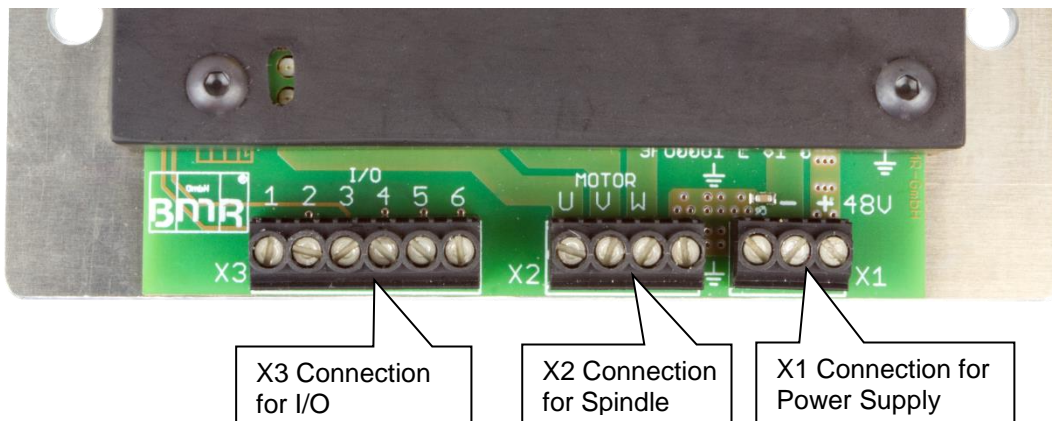

The PE connections of spindle and power supply can be connected at X2.  
 For a good shield connection, the mounting plate must be mounted electrically conductive. The shield connections of the connection cables must be grounded over a large area with or in the direct vicinity of the mounting plate.  
 If no spindle is connected OUT1 is activated and LED2 (red) is blinking (→4.4).



#### **Attention:**

Before commissioning, please make sure that all connection voltages are correct in value and polarity.  
 Connection X1 has no protection against reversed polarity !



#### **Attention:**

After connecting the spindle, always check the direction of rotation and correct if necessary.

#### **Attention:**

When using wire end ferrules, the maximum permissible connection cross-section of 0.75mm<sup>2</sup> must be observed

## 5. Functions, Setup and Operation

### 5.1 Start / Stop

There are two possibilities to start the spindle:

**digitally** with a digital control signal at digital input1 **Start/Stop** at X3.DIG\_IN.

The switching levels for "OFF=0" are 0...5V and for "ON=1" 13...24V,

Voltage level between 5V and 13V are undefined.

→ As soon as this is initiated, the spindle will be accelerated to the set value of the rotational speed which is pre-selected as voltage at analogue input **Set Value of Rotational Speed** at X3.ANL\_IN.

**analogue** with a voltage at X3.ANL\_IN

Precondition is a valid "ON" signal at digital input **Start/Stop** X3.DIG\_IN

→ An input voltage of 0V makes the spindle stop, and a voltage higher than 0,33V starts the spindle up to a rotational speed according to the scaling.

### 5.2 Set Value of Rotational Speed

At analogue input X3.ANL\_IN

**0-10V/ Min-Max:** The scaling for the analogue value is depending on the Min and Max values of the rotational speed in the spindle characteristic. We have here:

Min: 2.000rpm, Max: 100.000rpm. Over this range the control voltages can be calculated with

$$U_{ANL\_IN} = \text{Duty Value} * 10V / 100.000\text{rpm}$$

And the min speed is:  $\text{MinDrz} = 2.000\text{rpm} * 10V / 100.000\text{rpm} = 0,20V$

A voltage of  $U < 0,20V$  is standstill, a voltage of 0,20V sets the speed to 2.000 rpm, and 10V sets the speed to 100.000 rpm.

Analogue input schematic:

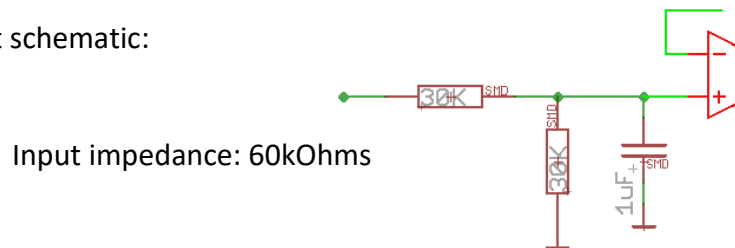

Input impedance: 60kOhms

### 5.3 Outputs

#### Digital Outputs:

As feedback to a PLC or another control unit there are available 2 Open Collector outputs (→4.4.)

Open Collector: 45V/0,5A

X3.OUT1      ***Inverter and Spindle Ready***

X3.OUT2      ***Overload***

Attention, the outputs are not protected against short circuits!

When operating inductive loads (e.g. relays), external protection diodes must be installed to protect the outputs.

## 5.4 LED Status Indication

At the LEDs the current operating status of the SFU0060 is indicated

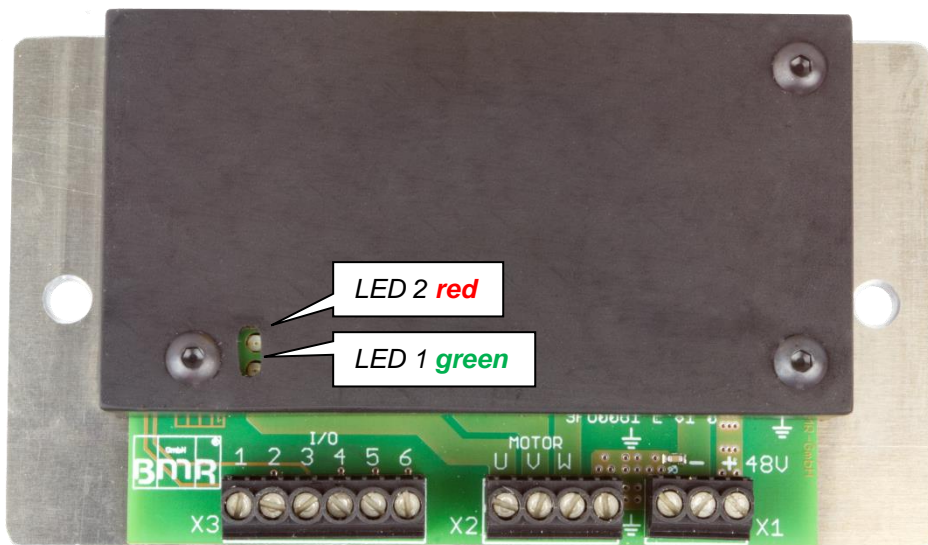

Status	LED 1 Green	LED 2 Red	Status
Ready	ON	OFF	Converter Standstill - No Error
Ready	Blink fast	OFF	Converter is accelerating- No Error
Ready	Blink	OFF	Set Value Duty Speed reached - No Error
Ready	Blink	ON	Overload Spindle - Duty Speed reached - Time Delay counting (1)(7)
Error-Standstill	ON	ON	Overload Spindle - Delay Time elapsed (1)(7)
Error-Standstill	ON	Blink slowly	Error Temperature Sensor Spindle - Switched off after elapsed delay time (7)
Error-Standstill	ON	Blink	No Spindle detected / Spindle Cable defective (2)
Error-Standstill	ON	Blink fast	Power Stage switched off - immediate shutdown with reaching the threshold (3)
Error-Standstill	ON	Blink long-short	too much back-energy of the spindle during ramp down - immediate shutdown (5)
Error-Standstill	OFF	Blink	Overtemperature SFU - switch off after elapsed Delay Time (6)(7)

(1) Overload spindle: (Switch off threshold depending on spindle parameter)

(2) All three output lines were tested with a test voltage. An Error is indicated, in case one or more phases do not have a proper current value

(3) Switch off threshold for power stage protection: 8A Max

(4) activation threshold for Brake Chopper: 54V

(5) activation threshold for Back-Energy: 58V

In case at ramp down the generated spindle voltage increases 58V

(6) Overtemperature error trip threshold for power stage: 70°C

(6) Overtemperature reset threshold for power stage: 67°C

(7) Adjustable in Menu "Delay Times"



## 5.5 Connection example for I/O

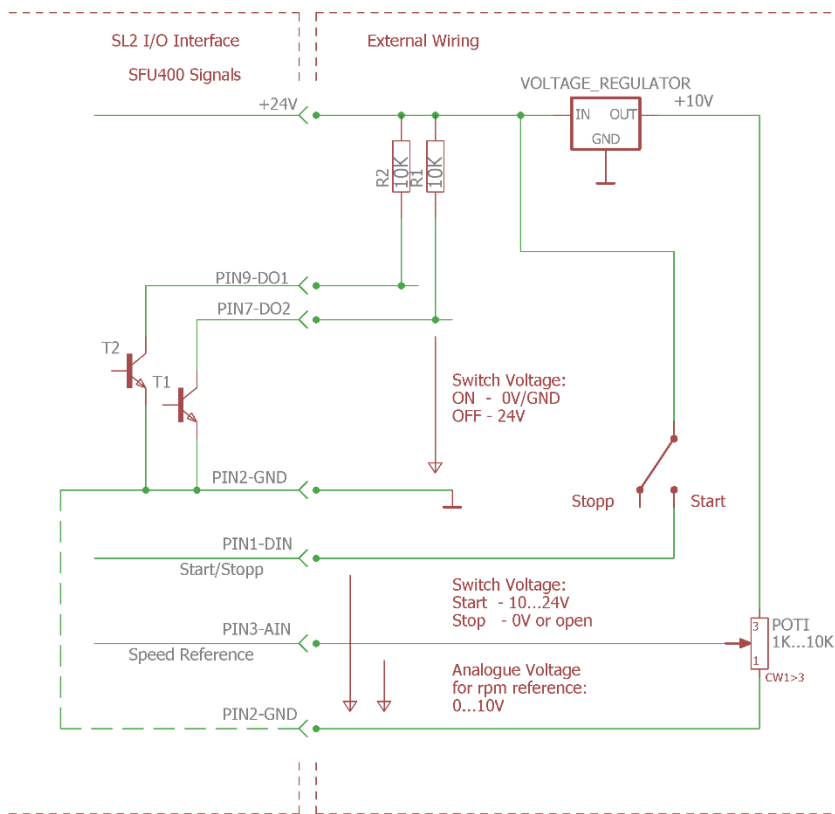

Example for connecting the I/O Interface

For a successful start of the spindle the analogue voltage at ANL\_IN has to be higher than the Min-Voltage for Stopp. (→ 5.2).

With using a potentiometer for dialing the rotational speed it should be wired to 10V, so that the required range from 0...10V can be covered, representing the speed range.



### **Attention:**

All these works handle with dangerous voltage and have to be carried out by skilled persons only.  
Please verify before connecting that the supply voltage is switched off!



### **Attention:**

Before commissioning, please make sure that all connection voltages are correct in value and polarity. Connection X1 has no reverse polarity protection



### **Attention:**

The outputs are not protected against short circuits!  
When operating inductive loads (e.g. relays), external protection diodes must be installed to protect the outputs

## 6. Safety Functions

The following safety functions bring about controlled stop of the spindle according predefined deceleration times:

- ✓ Safety Stop because of converter excess temperature after elapsed delay-time
- ✓ Safety Stop because of overload after elapsed delay-time (default 10sec)
- ✓ Immediate-Stop because of exceeding the maximum permissible spindle current
- ✓ When ramping down an asynchronous spindle it can happen that the voltage generated in the spindle will exceed the maximum permissible value. This is detected by the converter and the power stage is switched off for self protection.
- ✓ In this case, it has to be payed attention, because the spindle will run out uncontrolled for an undefined time, which can be quite long, depending on initial speed and tool properties. After standstill it can be restarted without problems.

## 7. EMC

- ✓ This device was developed for use **in industrial environments**. For trouble-free operation and to reduce emitted interference, the following should be observed during wiring of the equipment.
- ✓ The compliance with the limit values of EMC is the responsibility of the manufacturer of the machine or device.
- ✓ The EMC of a machine or device is affected by all connected components (motor spindle, length and type of cables, wiring, etc..). Under certain conditions the use of additional filters can be necessary to maintain the current laws.
- ✓ The earth and shield connections of all those devices used in conjunction with the frequency converter should be as short as possible and have as large a cross-section as possible.
- ✓ All external control units (PLC, IPC, CNC;...) being connected with the converter have to be connected to a common earth rail.
- ✓ For all connections, both to and from the frequency converter, should be used shielded cables and should be connected with earth on both sides .
- ✓ The shieldings should be connected with earth on both sides with low impedance and extensively.
- ✓ Supply cables, motor cables and control cables must be completely isolated from each other. Where crossing cannot be avoided, cables should be laid at 90° to each other.
- ✓ Control cables should be wired as far away as possible from load cables.
- ✓ The distance between load cables and control cables should be  $\geq 200\text{mm}$  (according DIN VDE 0100-444 because of possible high switching frequencies)

## 8. USB-Interface für SFU400

On option a remote control unit for direct interfacing with the I/O connection X3 is available.

Herewith the communication with the SFU terminal V7.5 for parameterization and debugging is possible very comfortably.

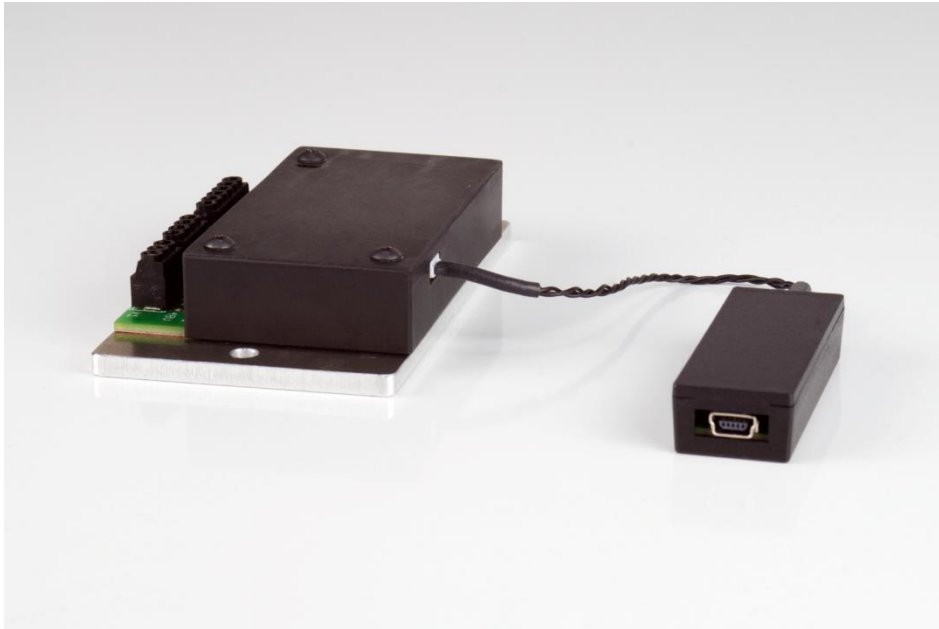

## 9. SFU400 with Remote Control-Adapter

On option a remote control unit for direct interfacing with the I/O connection X3 is available.

With the help of this unit the converter can be controlled very easily without any further wiring. Starting and stopping becomes possible and all functions can be tested before commissioning and without external control signals.



- ✓ The remote control unit is operated with 3 x AAA Batteries or Accus .
- ✓ All relevant voltages are generated within the adapter
- ✓ For power saving, an ON/OFF switch is provided. The ready state is indicated at the LED **Batt. ON**.
- ✓ The switch **START/STOP** applies a valid start voltage to the digital input and the converter can be started or stopped
- ✓ With the Poti **Rpm** can be setup the desired rotational speed with a 0-10V voltage at the analogue input. The **MIN** Position brings the converter to the stop state independent of the Start-switch position.
- ✓ The state of the digital outputs is indicated with the LEDs **DO1** und **DO2**.
- ✓ Assignment of the cable colours:

Yellow	Pin 1 DIG_IN
Grey	Pin2 ANL_IN
Green	Pin3 GND
Brown	Pin4 OC 1/OUT1
White	Pin5 OC 2/OUT2
(unconnected)	Pin6 PTC

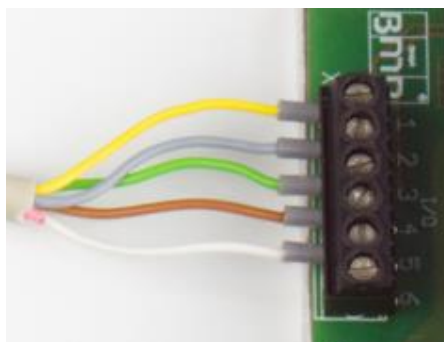

## 10. Dimensions and Mounting

For mounting the Open Frame Inverter, a 4mm hole is available at the end faces of the mounting plate

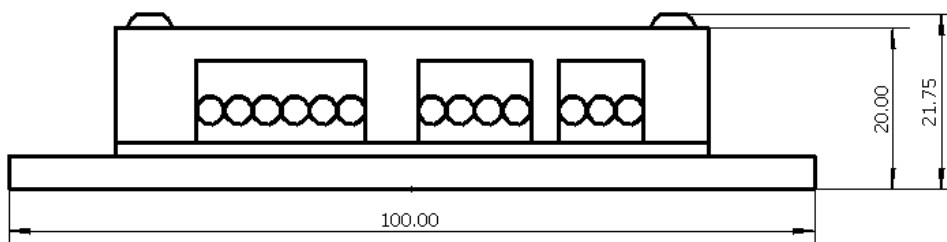
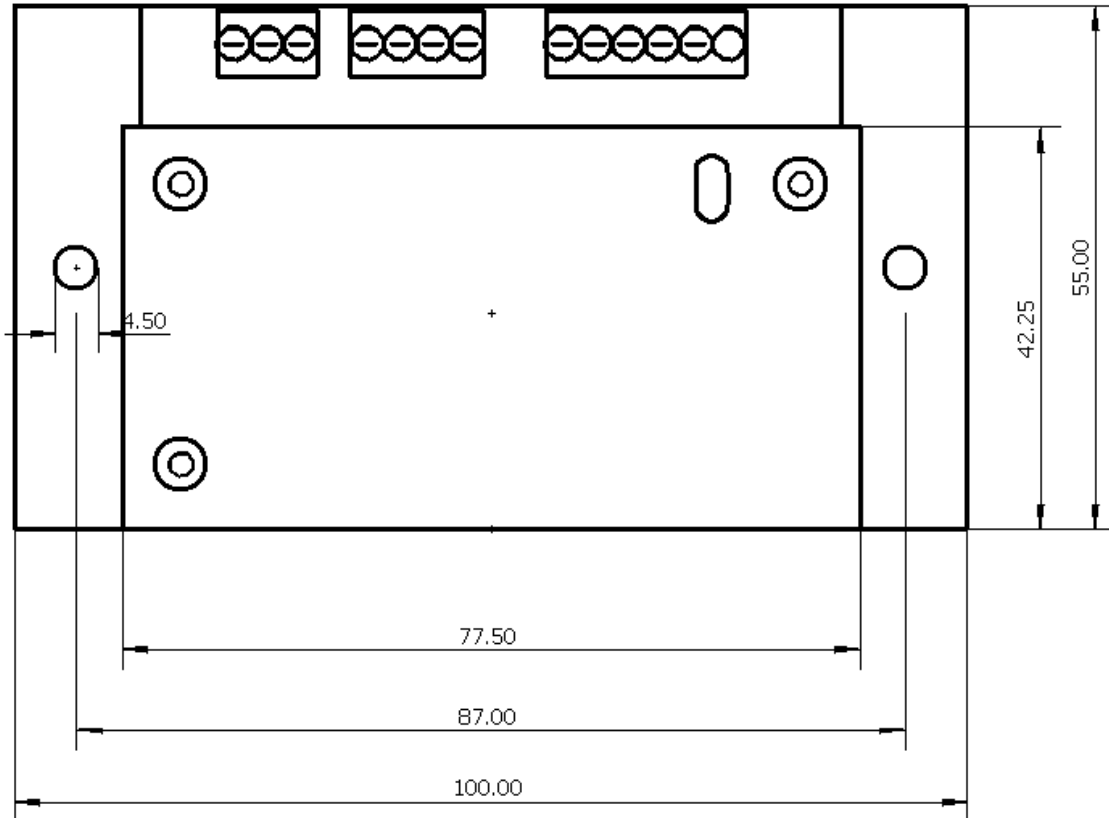





# CONTACT

FON 09122 / 631 48 - 0  
FAX 09122 / 631 48 - 29

**BMR GmbH**  
elektrischer & elektronischer Gerätebau  
**Walpersdorfer Straße 38**  
**91126 Schwabach**

E-Mail [info@bmr-gmbh.de](mailto:info@bmr-gmbh.de)  
Homepage [www.bmr-gmbh.de](http://www.bmr-gmbh.de)



**BMR Homepage**



**Manuals**

